



LineGrabber™ Installation and User's Manual # LG-2.01

LG-2WP
Wall Jack with
LineGrabber™ built-in



LG-2MSJ
IN-LINE
LineGrabber™



The **LineGrabber™** from **Alarm Network Devices, LLC** is a patented new concept of wireless telephone line anti-jam and seizure. It allows any alarm control panel to seize the phone line from other connected devices on the same line, without the installation of wiring to an RJ31X jack from the Telco Network Interface Box, (wireless installation) the alarm panel can be plugged into any existing jack or wired-in anywhere along the loop.

The UL LISTED LineGrabber™ works with most single-line analog (loop start) telephone equipment and systems. Installation is a snap, Just connect it in-line between the phone device and the wall jack. Adapters are available to use the LG-2MSJ with wall phones, also to connect more than one phone device to the LineGrabber™

Each in-line LineGrabber™ LG-2MSJ provides jacks for easy in-line installation, a line cord and foam mounting tape.

The LG-2WP a wall jack with a built in LineGrabber™ for a permanent installation, also has wiring terminals for phone line input, front jack for phone devices, and a rear jack for the alarm panel if using the same wall plate jack.

IMPORTANT NOTE:

Each telephone device that shares the line with the alarm control panel must have a LineGrabber™, the control panel connects direct without a LineGrabber™

SAFETY INSTRUCTIONS:

BEFORE USING OR INSTALLING THE **LineGrabber™**, THE FOLLOWING BASIC SAFETY PRECAUTIONS SHOULD BE FOLLOWED TO REDUCE THE RISK OF FIRE, ELECTRIC SHOCK, OR INJURY TO PERSONS:

1. Follow all warnings and safety instructions.
2. Review the entire installation sheet as well as illustrations before installing and using this product
3. Please check all contents. If items appear missing or damaged, contact the supplier where you purchased the product, or contact AND LLC directly at 360-715-3755.
4. Do not install or use this product in a wet environment, such as near a sink, bathtub, or swimming pool.
5. Unplug this product from the wall jack before cleaning. Use only a damp cloth.
6. Never insert an object of any kind into this product. Damage to the connected device can occur.
7. There are no end-user adjustments.
8. Do not use this product if it has been exposed to spilled liquid, rain, or water.
9. Do not use this product if it appears damaged or does not perform properly.
10. Avoid using this product and other connected devices during an electrical storm.
11. Never use a telephone or connected device to report a gas leak from near the leak area.

UL COMPLIANCE REQUIREMENTS:

1. LineGrabber™ requires a #26 AWG (or larger) telephone cord rating with no more than 1 (ohm) internal resistance.
2. Phone cable between the LINEGRABBER and the phone device must have the release tabs on the RJ11 plugs clipped flush to each piece of equipment.
3. Supplied warning labels will be affixed to each unused wall-jack and each phone device connected with a LineGrabber™

UL Listed :

UL file # S8097 CONTROL UNIT ACCESSORY

UL 985 HOUSEHOLD FIRE WARNING SYSTEM UNITS

UL 1023 HOUSEHOLD BURGLAR ALARM SYSTEM UNITS

UL 1637 HOME HEALTH CARE SIGNALING EQUIPMENT

FCC:

This equipment complies with Part 68 of the FCC rules and the requirements adopted by **ACTA**. On the [insert location of the label] of this equipment is a label that contains, among other information, a product identifier in the format **US: ALMOT01BLG2WP-MSJ** and Ringer Equivalence Number (REN) for this equipment. You must, upon request, provide this information to your telephone company.

RINGER EQUIVALENCE NUMBER:

The REN is useful to determine the quantity of devices you may connect to your telephone line and still have those devices ring when your telephone number is called. In most, but not all areas, the sum of the REN'S of the number of devices connected to one line should not exceed five (5.0). To be certain of the number of devices you may connect to your line, as determined by the REN, you should contact your local telephone company to determine the maximum REN for your area.

If your telephone causes harm to the telephone network, the telephone company may discontinue your service temporarily. If possible, they will notify you in advance. But if advance notice isn't practical, you will be notified as soon as possible. You will be informed of your right to file a complaint with the FCC. Your telephone company may make changes in its facilities, equipment, operations, or procedures that could affect the proper functioning of your equipment. If they do, you will be notified in advance to give you an opportunity to maintain uninterrupted telephone service. If you experience trouble with this telephone equipment, the telephone company may ask that you disconnect this equipment from the network until the problem has been corrected, or until you are sure that the equipment is not malfunctioning. This equipment may not be used on coin service or party lines provided by the telephone company.

Typical LG-2 LineGrabber™ Installation

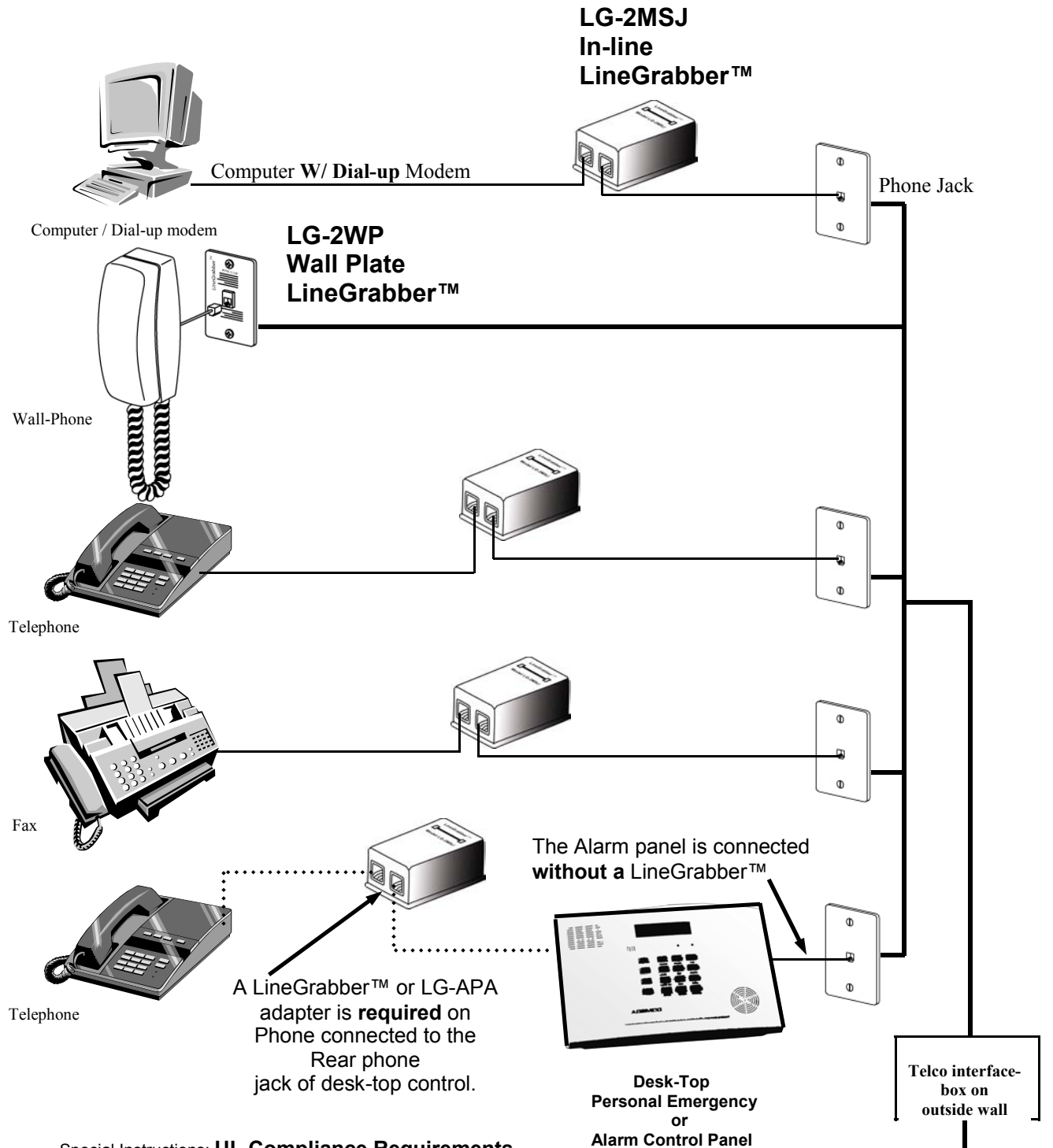

Special Instructions: **UL Compliance Requirements.**

- Use # 26 AWG or larger phone cords with RJ11 connectors and **cut the release tabs on all RJ11 plugs.**
- Supplied Warning labels will be affixed to each unused wall-jack and each phone device connected with a LineGrabber™.

The LineGrabbers™ are labeled with specific ends for the line coming from the wall, and the line coming from the phone. If your phone does not work after installation, reverse LineGrabber™ wall and phone RJ11 plugs. (Wall Jack may be wired backwards)

Typical LG-2 LineGrabber™ and DSL filter Installation

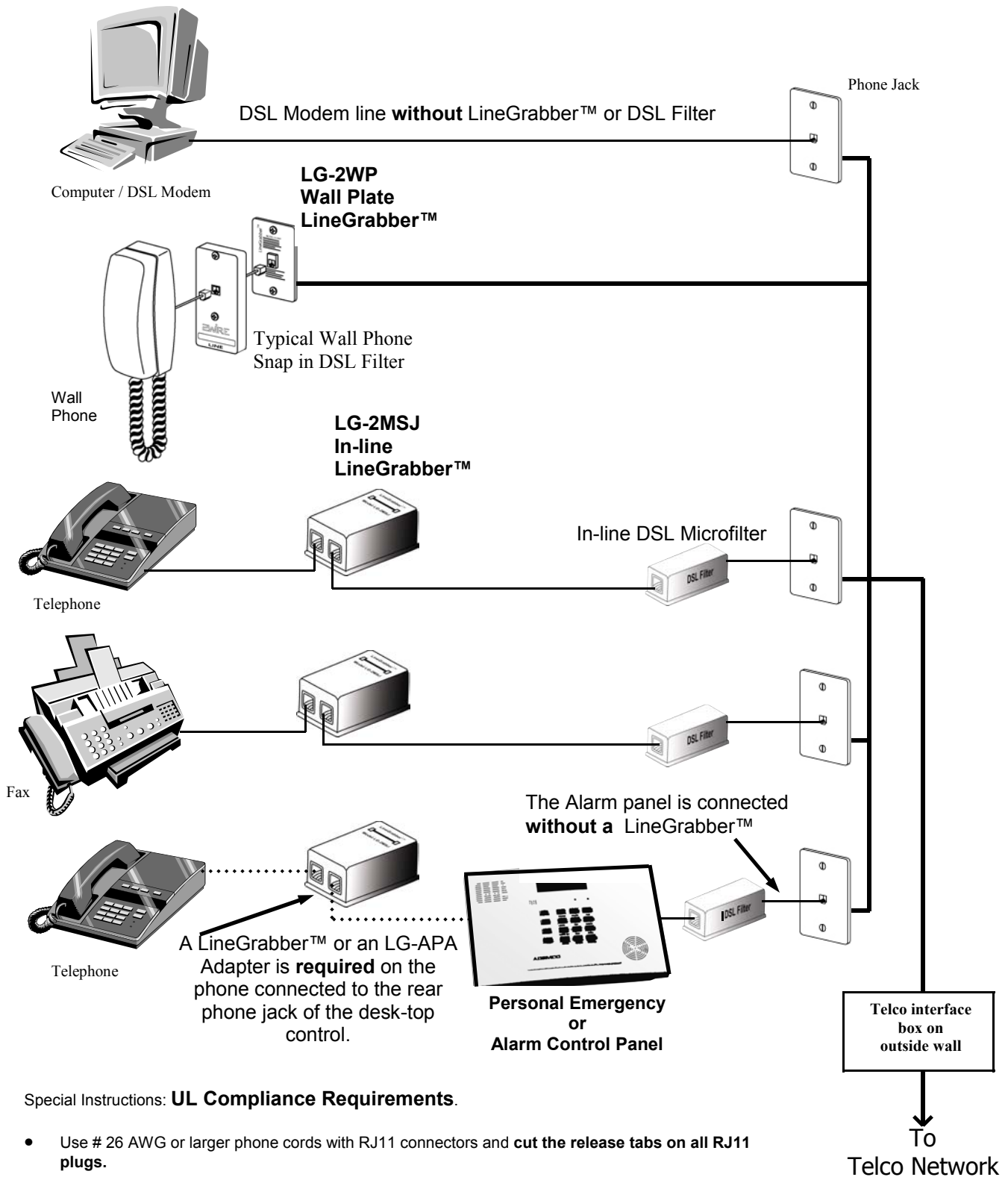

Special Instructions: UL Compliance Requirements.

- Use # 26 AWG or larger phone cords with RJ11 connectors and **cut the release tabs on all RJ11 plugs.**
- Supplied Warning labels will be affixed to each unused wall-jack and each phone device connected with a LineGrabber™

The LineGrabbers™ and microfilters are labeled with specific ends for the line coming from the wall, and the line coming from the phone. If your phone does not work after installation, reverse LineGrabber wall and phone RJ11 plugs. (wall jack may be wired backwards)

Several Phone Devices connected to one LineGrabber™.

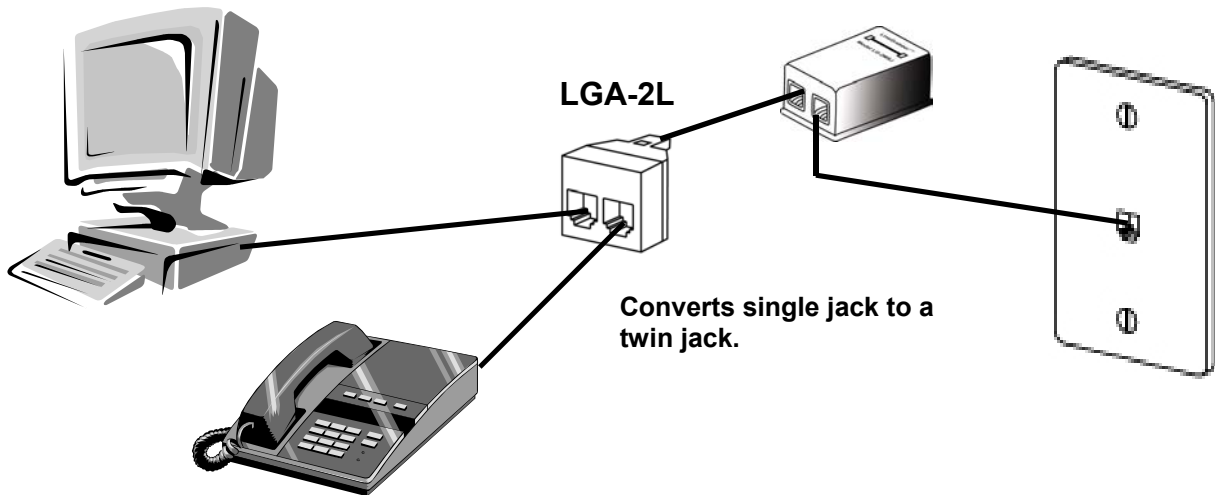

Connect LineGrabber™ to line 2 of 2 line jack.

Converts a single dual line jack to two single line jacks.
Lets you connect a LineGrabber™ to line 2.

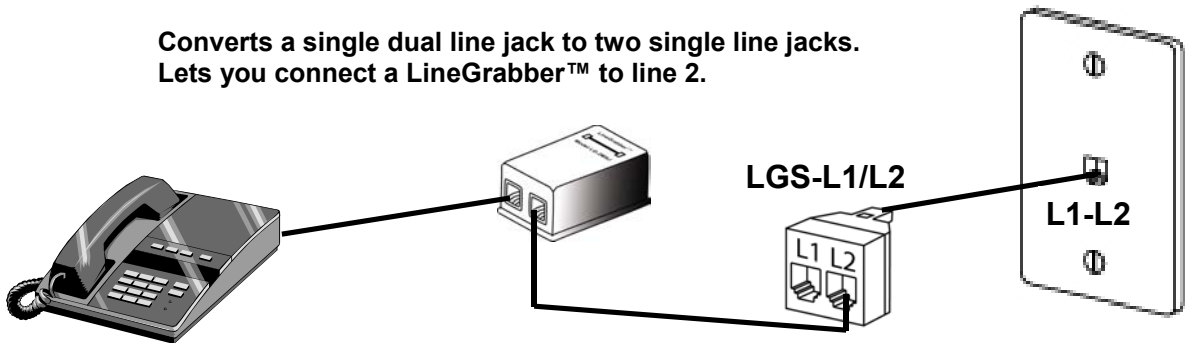

LG-2WP Wall Plate LineGrabber™

Install in single gang box. Use with Wall Phone or To replace standard wall jacks for a permanent LineGrabber™ installation.

LG-2WP
WALL JACK WITH
LINEGRABBER™

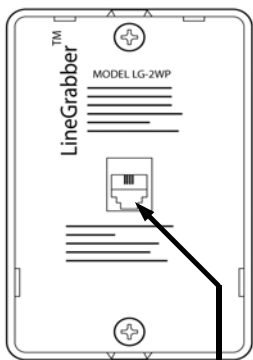

**FRONT
COVER OFF**

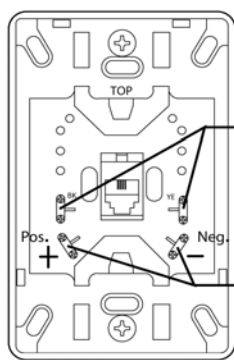

Connect a second phone line that does not have alarm system here.

Connect phone line with alarm control communicator here, **OBSERVE POLARITY.**

BACK

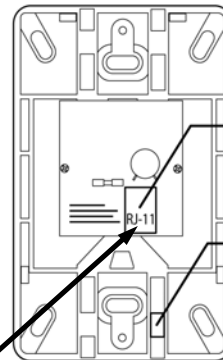

Alarm control plugs in here.

To install cable with plug already installed, cut-out partition and route cable through the channel.

Connect to terminals

Or

Plug-in with RJ11 plug



Two-Year Limited Warranty:

Alarm Network Devices, LLC. (AND) warrants that equipment and products manufactured by AND (AND Product) will be free from defects in material and workmanship for two (2) years from the date of purchase by the original purchaser.

This Limited Warranty extends only to the original purchaser and does not extend to consumers, end users, or other secondary purchasers of AND Product. Consumers or end users should contact their selling dealer as to the nature and extent of the dealer's warranty, if any apply.

AND's obligation under this Limited Warranty is limited to the repair or replacement, at AND's option, of any defective AND Product at no additional charge. AND reserves the right to replace AND Product under this Limited Warranty with new or remanufactured product. AND will not be responsible for labor costs of removal or reinstallation of AND Product.. The repaired or replaced AND Product is than warranted under the terms of this Limited Warranty for the balance of the term of this Limited Warranty or for ninety (90) days, whichever is longer.

AND is not responsible for conditions or applications over which AND has no control. Defects or problems as a result of such conditions or applications are not the responsibility of AND. Such conditions or applications include normal wear and tear, catastrophe, fault or negligence of the user or the original purchaser, improper installation, application, maintenance or use of AND Product, or other causes external to AND Product.

If you have any warranty claim, please contact AND at 360-715-3755 and request authorization to return the AND Product. We will issue you a Return Merchandise Authorization (RMA) number. Return the AND Product, freight prepaid, to AND together with reference to the RMA number and a written explanation setting forth the potential defect in reasonable detail.

The original purchaser's exclusive remedy with respect to any and all losses or damages resulting from any cause whatsoever shall be repair or replacement as specified above. AND shall in no event be liable for any consequential or incidental damages, however occasioned, whether by negligence or otherwise. Some states do not allow the exclusion or limitation of incidental or consequential damages, so this limitation or exclusion may not apply to you.

The foregoing limited warranty is in lieu of all other warranties, express or implied, and no person (including any agent, dealer or representative of AND) is authorized to make any representation or warranty concerning AND product except to refer original purchasers to this limited warranty. Any implied warranties (including, without limitation, any implied warranties of merchantability or fitness for a particular purpose) are limited to the duration of this limited warranty. Some states do not allow limitations on how long an implied warranty lasts, so this limitation may not apply to you. This limited warranty gives you specific legal rights. You may also have other rights, which vary from state to state.

U.S. Patent # 5,799,062



**1709 Kentucky St.
Bellingham, WA 98229-4714**

Telephone: 360-715-3755 Fax: 360-647-9698

E-Mail andllc@qwest.net www.linegrabber.com